

## 2. MOUNTING DRAWING

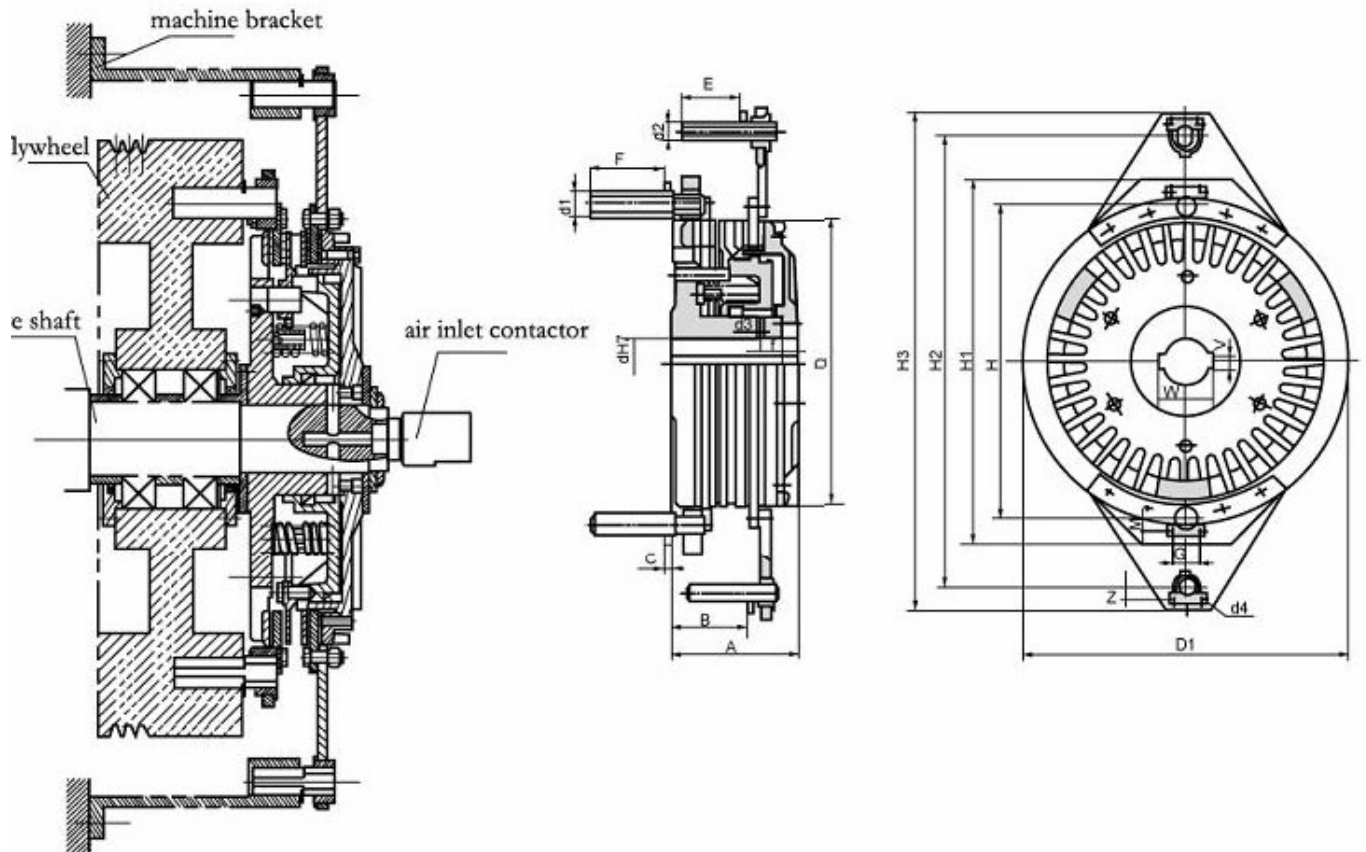

MODEL	A	B	C	D	D1	E	F	H	H2	H3	d	d1	d2	d3	f	mark
LZ188	37.5			188	220	30	30	250	250	280	30~36	14	14	6	16.5	
LZ236	66	31	8	236	275	25	45	315	410	442	30~40	22	18	7	18	
LZ265	72	28.5		265	305	45		283	345	390	30~50	M6	22	7	18	
LZ304	84	46	3	304	347	45	65	390	490	522	45~65	22	14	12	26	
LZ340	87	45	10	340	392	60	60	390	530	588	50~70	22	22	12	26	
LZ380	100	48	10	380	435	60	60	445	660	726	60~80	30	30	14	27	
LZ430	100	55	6	430	485	60	60	490	670	730	70~90	35	32	14	27	
LZ465A	118	55	30	465	530	65	60	520	730	786	70~95	35	35	14	33	
LZ465B	118	55	30	465	530	65	60	520	620	700	70~95	35	35	14	33	
LZ500	140	75	2	500	570	60	80	570	790	856	75~100	40	30	17	36	
LZ550	150	75	3	550	620	60	90	630	900	970	80~110	45	35	18	40	
LZ600	168	80.5	6.5	600	690	70	75	684	1000	1080	80~110	45	38	18	43	
LZ685A	180	87	12.8	685	780	87	75	820	1100	1240	120~145	50	50	20	55	
LZ685B	190	87	12.8	685	780	87	75	820	1200	1360	120~145	50	50	20	60	
LZ685.S	245	132	13	685	780	80	80	820	1100	1240	120~145	50	50	20	55	
LZ755	205	111	6	755	865	110	110	855	1200	1360	130~150	50	50	20	55	
LZ755.S	245	139	6	755	865	110	110	855	1200	1340	130~150	50	50	20	55	

**Los valores de torque están tomados con una presión de 0.55 Mpa**

Lz340 para	60 ton	torque de freno	537 y 2370	torque de embrague
Lz470 para	100ton	torque de freno	3303 y 5630	torque de embrague
Lz600 para	150ton	torque de freno	9306 y 9943	torque de embrague
Lz685 para	250ton	torque de freno	7249 y 18670	torque de embrague
Lz685s para	mas de 250ton	torque de freno	9261 y 33189	torque de embrague

**1. TORQUE REFERENCE (ATMOSPHERIC PRESSURE: 0.55Mpa)**

SPEC		LZ188	LZ236	LZ265	LZ304	LZ340	LZ380	LZ430	LZ465	LZ470	LZ500	LZ550	LZ600	LZ685	LZ685S	LZ755	LZ755S
clutch	n=15	318	752	867	1423	2370	2590	3505	4350	5630	6250	6805	9943	18607	33189	36146	67809
torque	n=18	285	690	785	1280	2239	2277	3055	3700	4923	5664	5845	8005	17036	29242	33710	62040
brake	n=15	108	290	348	612	537	1437	2094	3053	3303	2767	4500	9306	7249	9261	11421	13113
torque	n=18	130	348	418	735	645	1737	2513	3664	3960	3321	5400	11168	8699	11113	13705	15735

n: spring number